

FETTEC 1404T-3850KV

Technical Datas

KV	3850
Configu-ration	9N12P
Stator Diamter	14mm
Stator Length	4mm
Shaft Diameter	1.5mm (2mm inside)
Motor Dimension(Dia.*Len)	Φ 19.5*13.2mm
Weight(g)	9.5 (3cm wire)
Idle current(10)@10V(A)	0.6
No.of Cells(Lipo)	3S-4S
Max Continuous Power(W)3S	185
Internal Resistance	270mΩ
Max Current(3S)	13.5A
Max.Efficiency Current	(2-4A)>83%

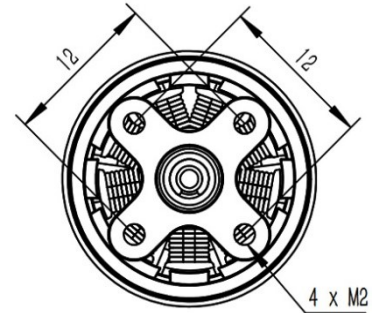
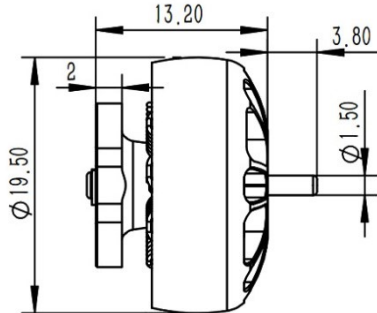
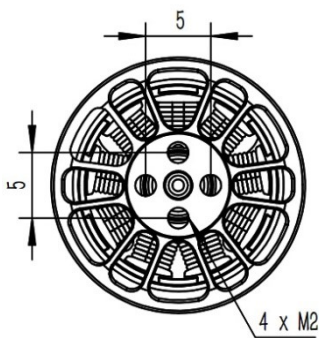

Prop (inch)	Voltages (V)	Throttle (%)	Load Currency (A)	Pull(g)	Power(W)	Efficiency(g/W)	Temperature(in full throttle load 3 Secs)
GF2.5*4*3	12.6	50%	0.75	75	9.5	7.937	52°C
		100%	4.8	220	60.5	3.638	
	16.8	50%	1.6	122	20.2	6.052	62°C
		100%	8.3	348	104.6	3.328	
HQ 3*2.5*3	12.6	50%	1.6	115	20.2	5.704	63°C
		100%	8.8	310	110.9	2.796	
	16.8	50%	2.7	177	45.4	3.902	78°C
		100%	12.6	444	211.7	2.098	
HQ 3*3*3	12.6	50%	1.9	122	23.9	5.096	65°C
		100%	9.1	322	114.7	2.808	
	16.8	50%	3.2	194	53.8	3.609	81°C(HOT)
		100%	13.5	463	226.8	2.041	
GF4*2*2	12.6	50%	2.3	169	29.0	5.832	68°C
		100%	10.4	407	131.0	3.106	